

**SECTION**

**TYP. DOUBLE TEE - I.T.BEAM CONNECTION**

SCALE: 3/4" = 1'-0"

**STRESS-CON**  
INDUSTRIES, INC.

MAIN OFFICE:  
50500 DESIGN LANE TEL: (586) 731-1628  
SHELBY TOWNSHIP, MI 48315 FAX: (586) 731-7007  
WWW.STRESSCONINDUSTRIES.COM

PROJECT NO.

DRAWN

SCALE

CHECKED

DATE

ISSUED FOR

REF.

PROJECT

SHEET NO.

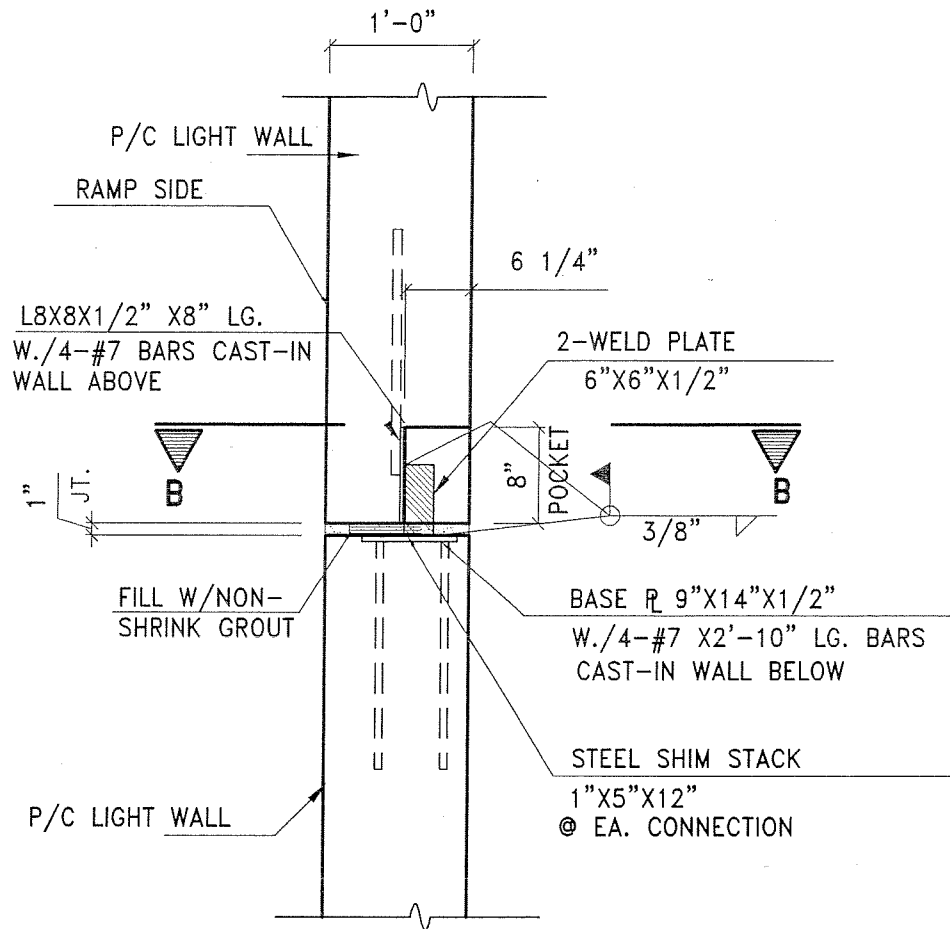

**TYP. LIGHT WALL TO LIGHT WALL CONN. @ EACH END**

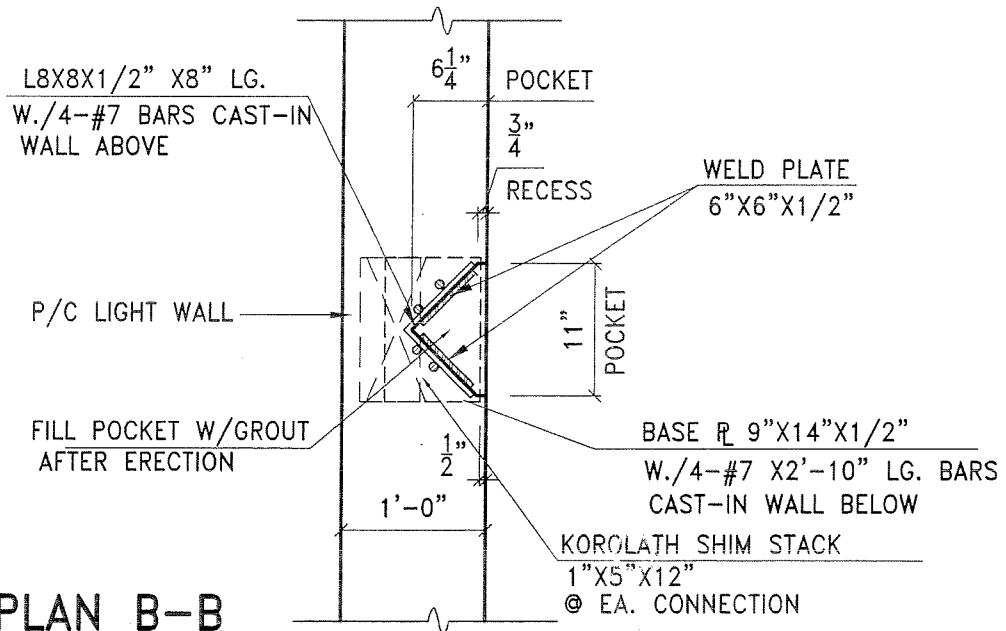

**PLAN B-B**

**STRESS-CON**  
INDUSTRIES, INC.

MAIN OFFICE:  
50500 DESIGN LANE TEL: (586) 731-1628  
SHELBY TOWNSHIP, MI 48315 FAX: (586) 731-7007  
WWW.STRESSCONINDUSTRIES.COM

PROJECT NO.

DRAWN

SCALE

CHECKED

DATE

ISSUED FOR

REF.

PROJECT

SHEET NO.

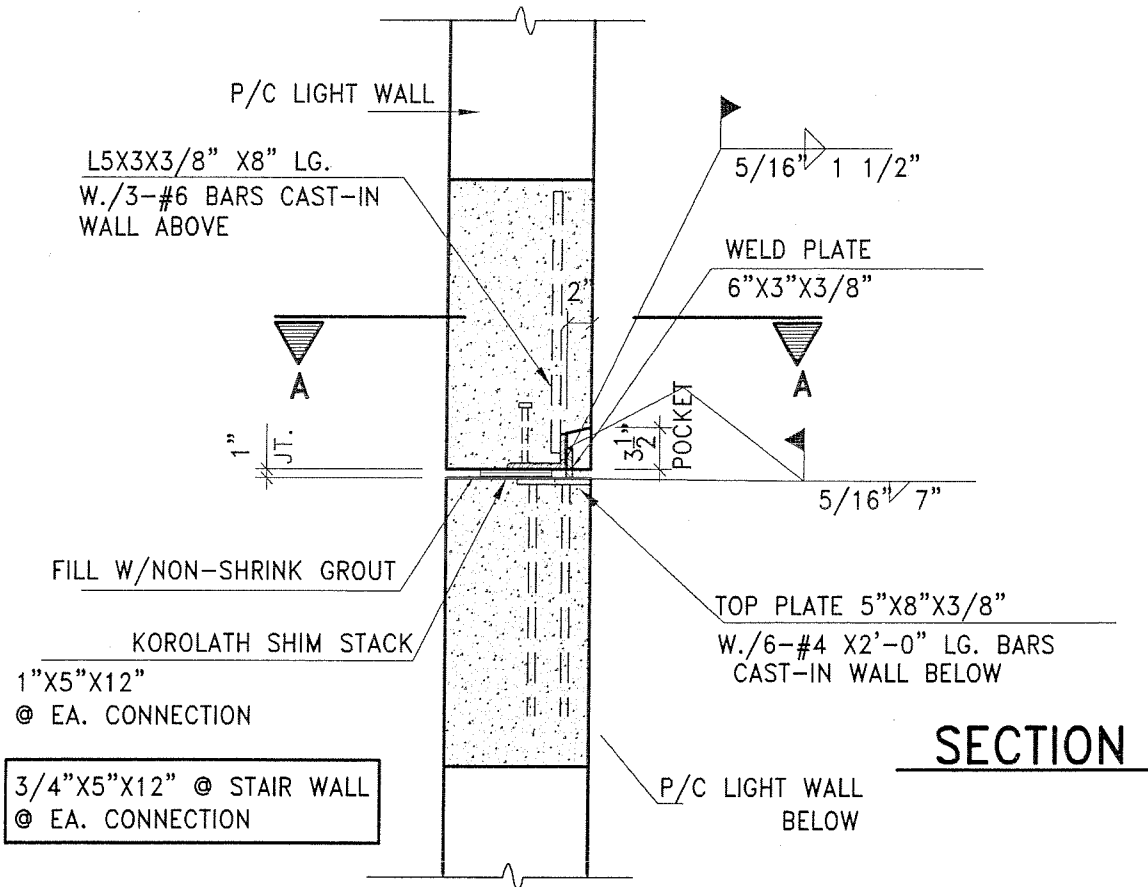

3/4"X5"X12" @ STAIR WALL  
@ EA. CONNECTION

**SECTION**

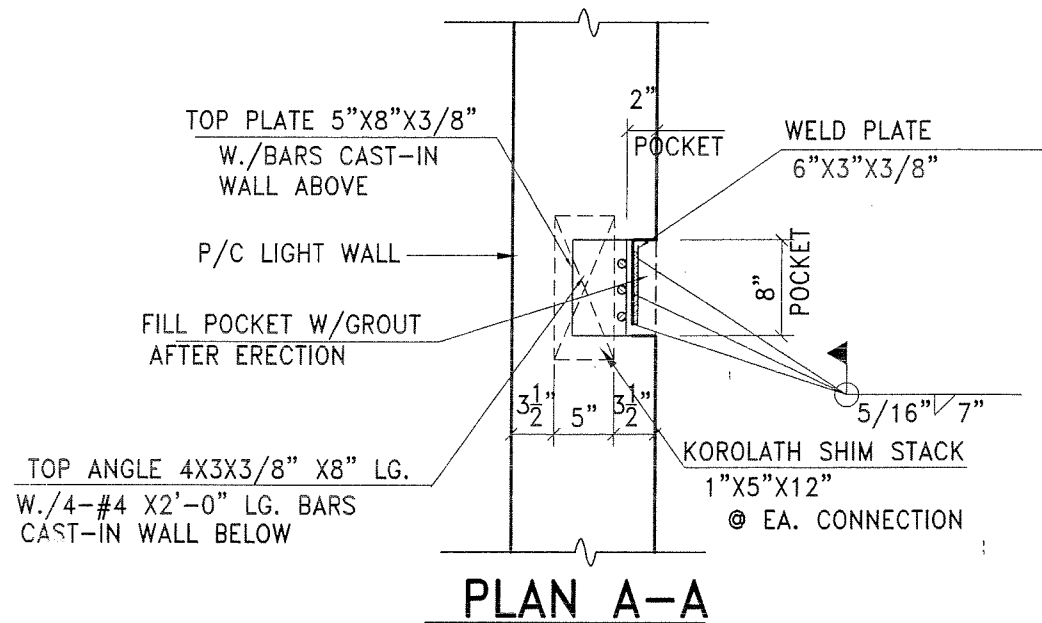

**PLAN A-A**

**TYP. LIGHT WALL TO LIGHT WALL /STAIR WALL**

SCALE: 3/4" = 1'-0"

<b>STRESS-CON</b> INDUSTRIES, INC.	MAIN OFFICE: 50500 DESIGN LANE SHELBY TOWNSHIP, MI 48315 WWW.STRESSCONINDUSTRIES.COM	TEL: (586) 731-1628 FAX: (586) 731-7007	PROJECT NO.		DRAWN
			SCALE		CHECKED
			DATE	ISSUED FOR	REF.
					SHEET NO.

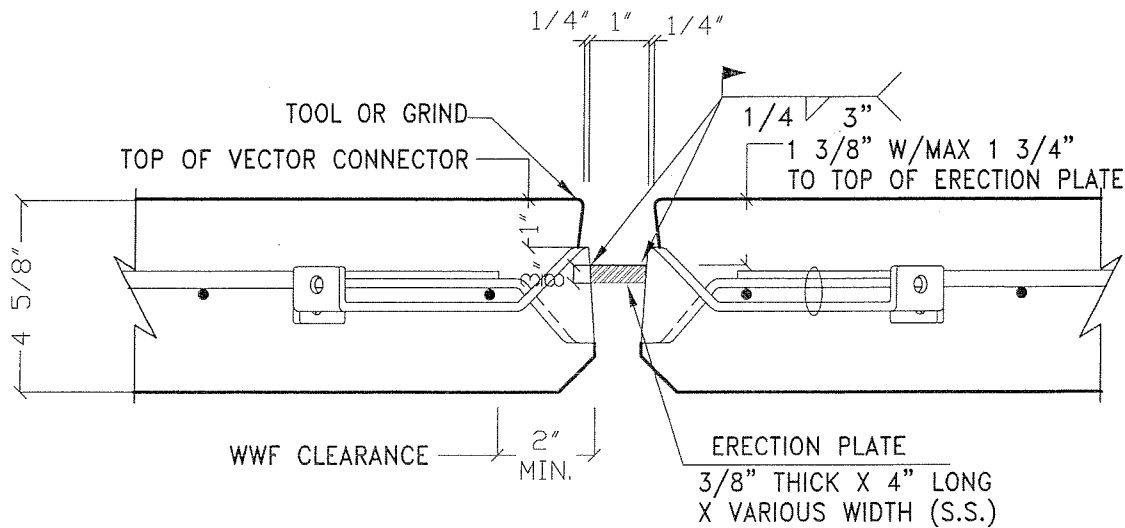

## VECTOR CONNECTOR NEGATIVE DRAFT

**NOTES:**

- 1.) CENTER WELD AND FIELD PLATE WITHIN FACEPLATE OF VECTOR CONNECTOR. DO NOT WELD AT CORNERS.
- 2.) DO NOT OVER WELD; 3" MAXIMUM WELD LENGTH.
- 3.) FIELD PLATE TO BE HORIZONTAL.
- 4.) TOP EDGE OF VECTOR CONNECTOR MUST BE CLEAN.
- 5.) LOCATE LONGITUDINAL AND TRANSVERSE WIRE OF WWF MESH SO NOT TO INTERFERE WITH VECTOR CONNECTOR LEG ENDS; ORDER WWF MESH WITH PROPER CLEARANCE.
- 6.) DETAIL OF JOINT BEYOND NOT SHOWN; SEE JVI-SK3
- 7.) FOR A304 STAINLESS STEEL VECTOR CONNECTORS, USE A304 STAINLESS STEEL ERECTION PLATES AND USE WELDING ELECTRODE E308.
- 8.) FOR "J" COATED VECTOR CONNECTORS (A36), USE A36 GRADE ERECTION PLATES AND USE WELDING ELECTRODE E70XX.

CONNECTION AT EACH  
DOUBLE TEE JOINT AT  
4'-0" ON CENTER

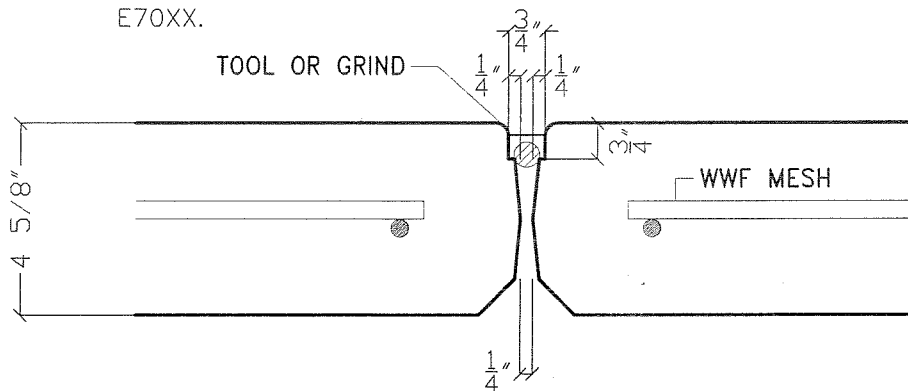

### JOINT DETAIL BEYOND CONNECTION

## TYP. D-TEE TO D-TEE FLANGE CONNECTION

SCALE: 3/4" = 1'-0"

**STRESS-CON** **INDUSTRIES, INC.**

MAIN OFFICE:  
50500 DESIGN LANE TEL: (586) 731-1628  
SHELBY TOWNSHIP, MI 48315 FAX: (586) 731-7007  
WWW.STRESSCONINDUSTRIES.COM

PROJECT NO.

DRAWN

SCALE

CHECKED

DATE

ISSUED FOR

REF.

PROJECT

SHEET NO.

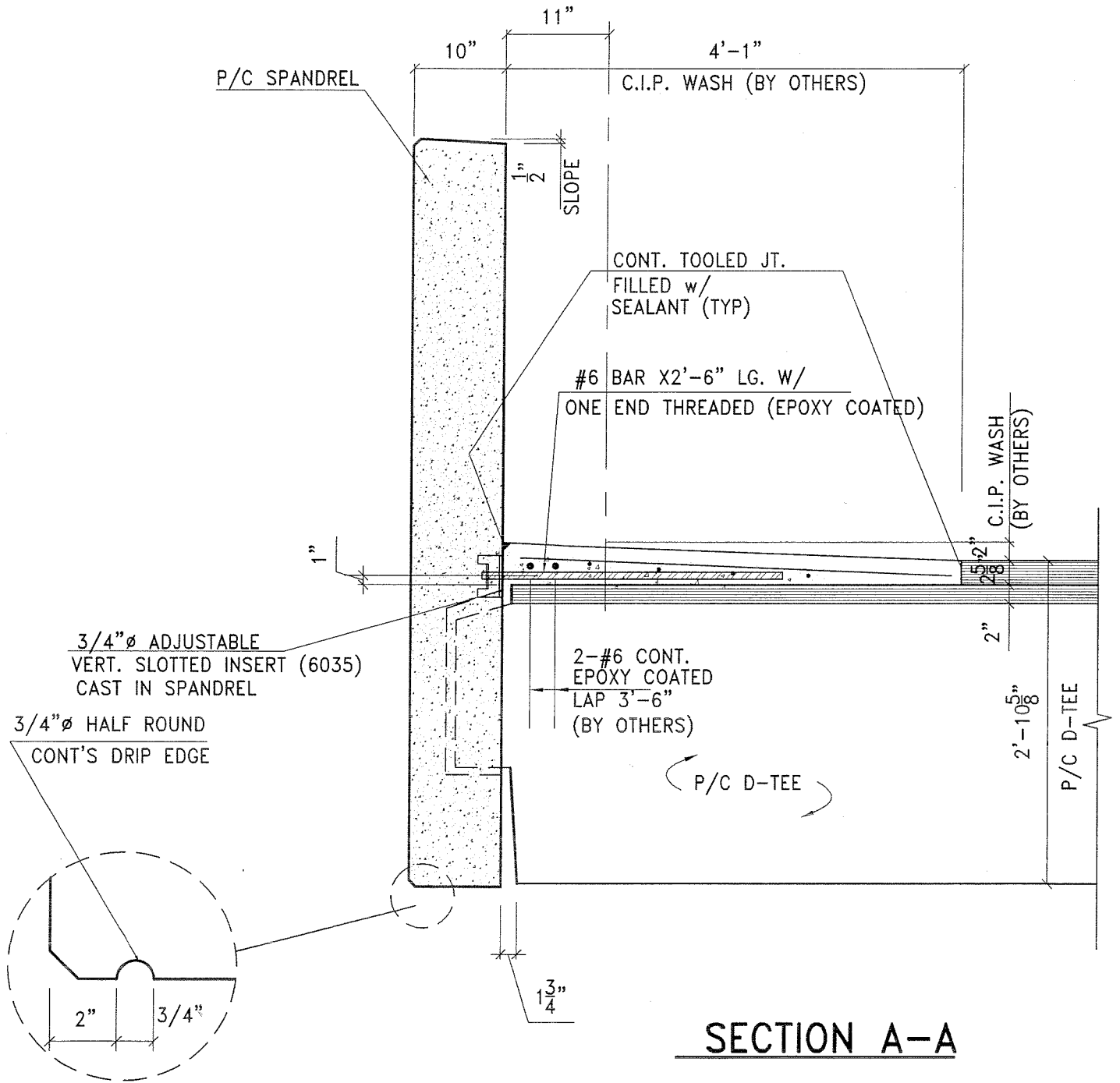

**TYP. D-TEE-SPANDREL CONN.**

SCALE: 3/4" = 1'-0"

**STRESS-CON**  
INDUSTRIES, INC.

MAIN OFFICE:  
50500 DESIGN LANE TEL: (586) 731-1628  
SHELBY TOWNSHIP, MI 48315 FAX: (586) 731-7007  
WWW.STRESSCONINDUSTRIES.COM

PROJECT NO.

DRAWN

SCALE

CHECKED

DATE

ISSUED FOR

REF.

PROJECT

SHEET NO.

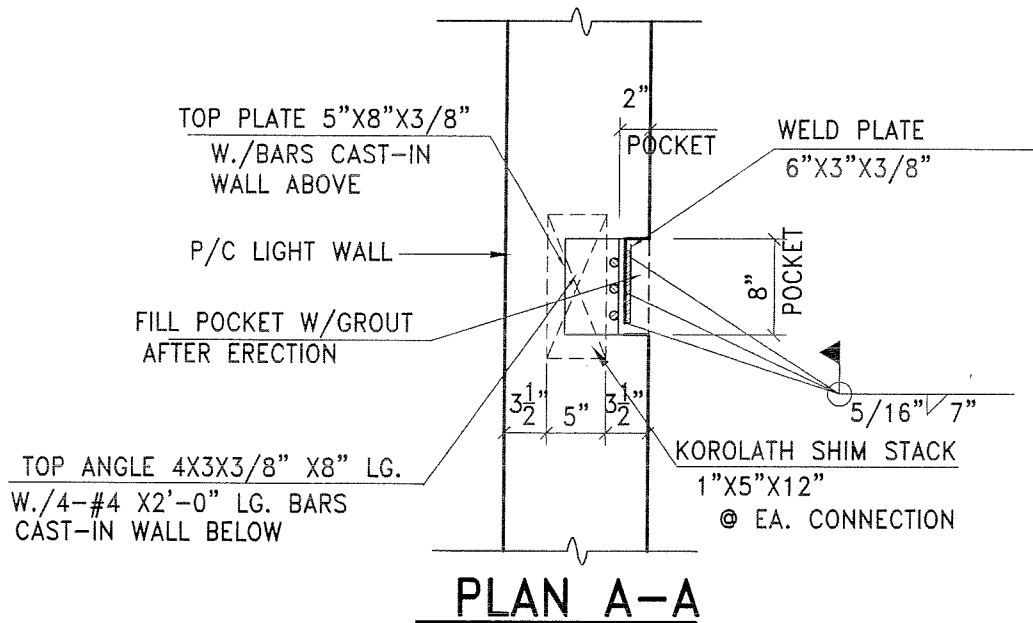
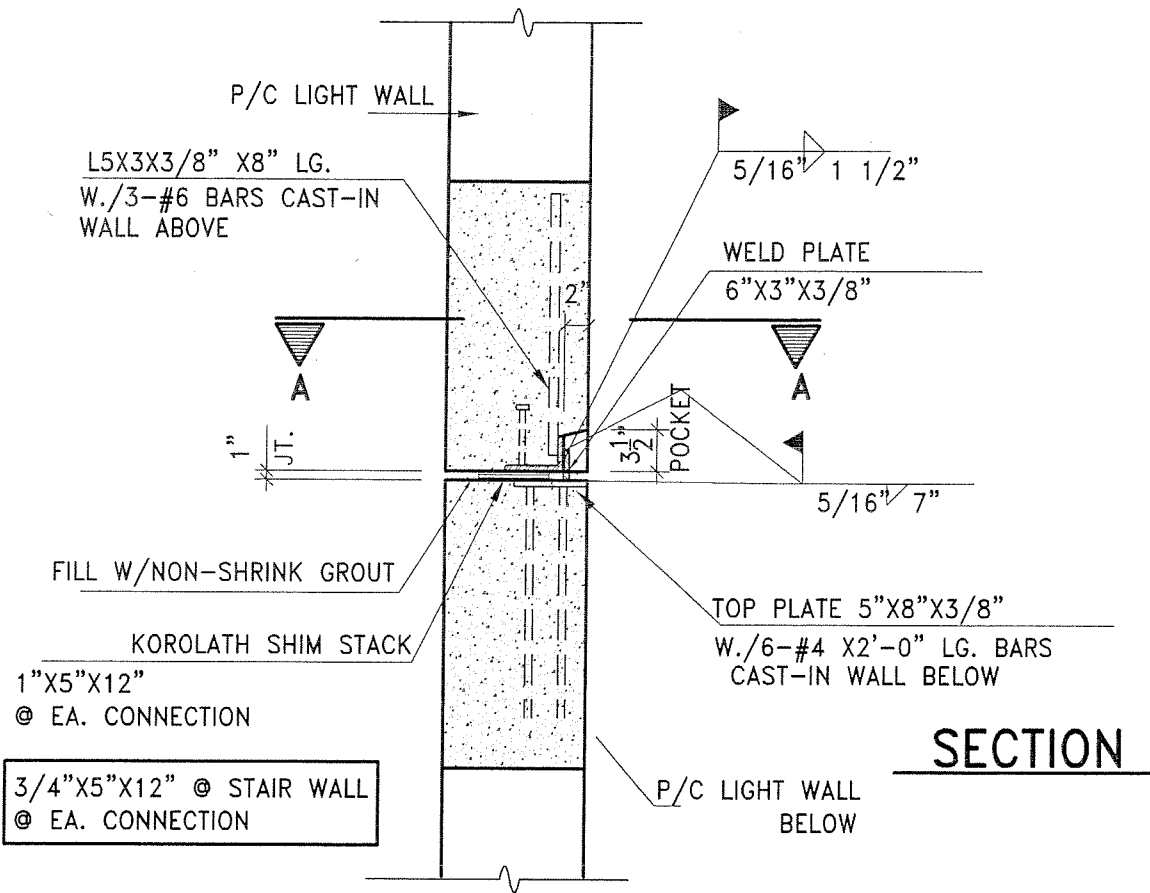

**TYP. LIGHT WALL TO LIGHT WALL /STAIR WALL**

SCALE: 3/4" = 1'-0"

**STRESS-CON**   
**INDUSTRIES, INC.**

MAIN OFFICE:  
50500 DESIGN LANE TEL: (586) 731-1628  
SHELBY TOWNSHIP, MI 48315 FAX: (586) 731-7007  
WWW.STRESSCONINDUSTRIES.COM

PROJECT NO.		DRAWN
SCALE		CHECKED
DATE	ISSUED FOR	REF.
		SHEET NO.

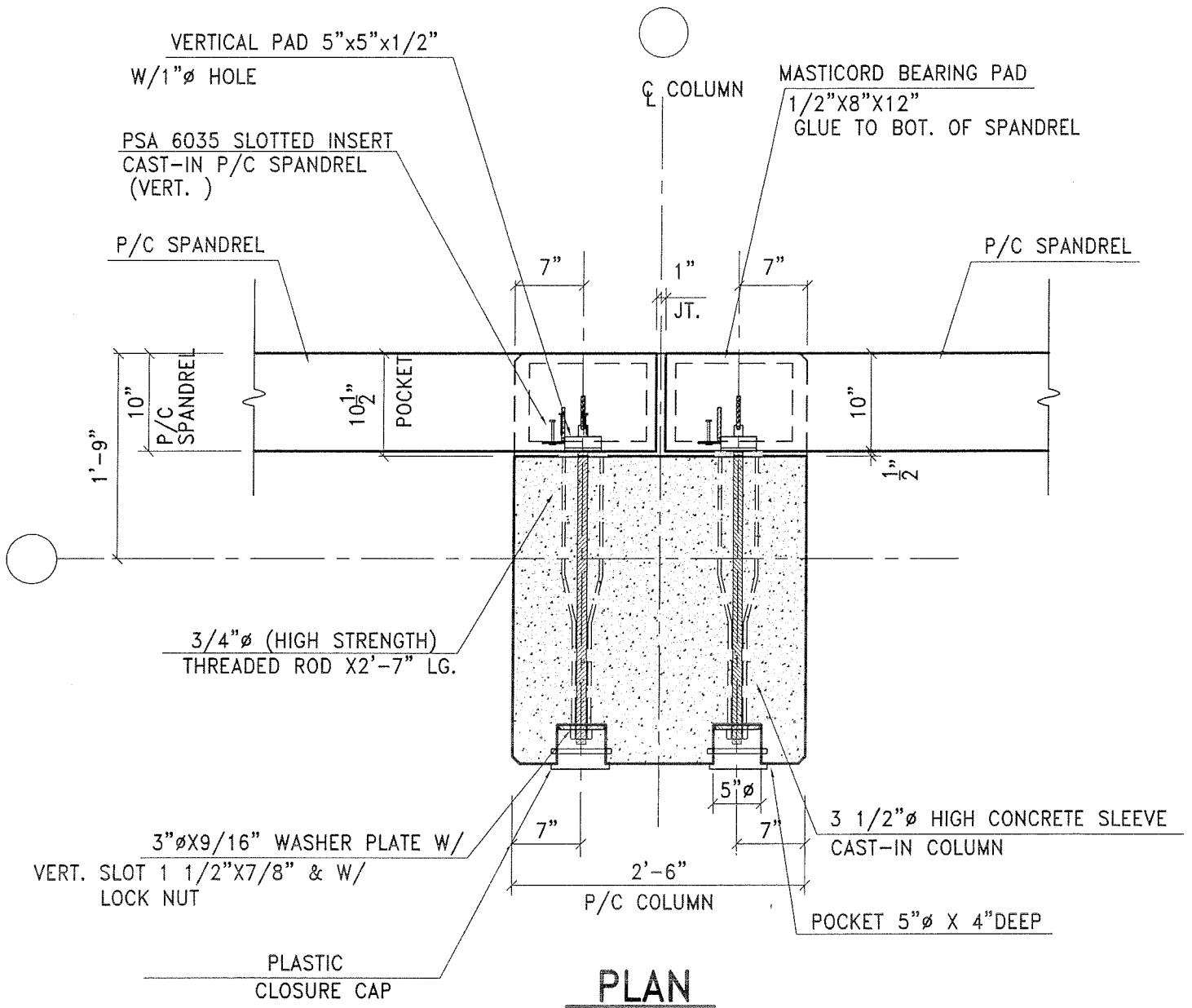

**NOTE:**  
 DOUBLE TEE ELEMENTS  
 NOT SHOWN FOR CLARITY.

## TYP. EXTERIOR COLUMN – SPANDREL CONNE.

SCALE: 3/4" = 1'-0"

**STRESS-CON**  
 INDUSTRIES, INC.

MAIN OFFICE:  
 50500 DESIGN LANE  
 SHELBY TOWNSHIP, MI 48315  
 TEL: (586) 731-1628  
 FAX: (586) 731-7007  
 WWW.STRESSCONINDUSTRIES.COM

PROJECT NO.	771	DRAWN	N.E.
SCALE		CHECKED	
DATE	ISSUED FOR	REF.	
			SHEET NO.

PROJECT

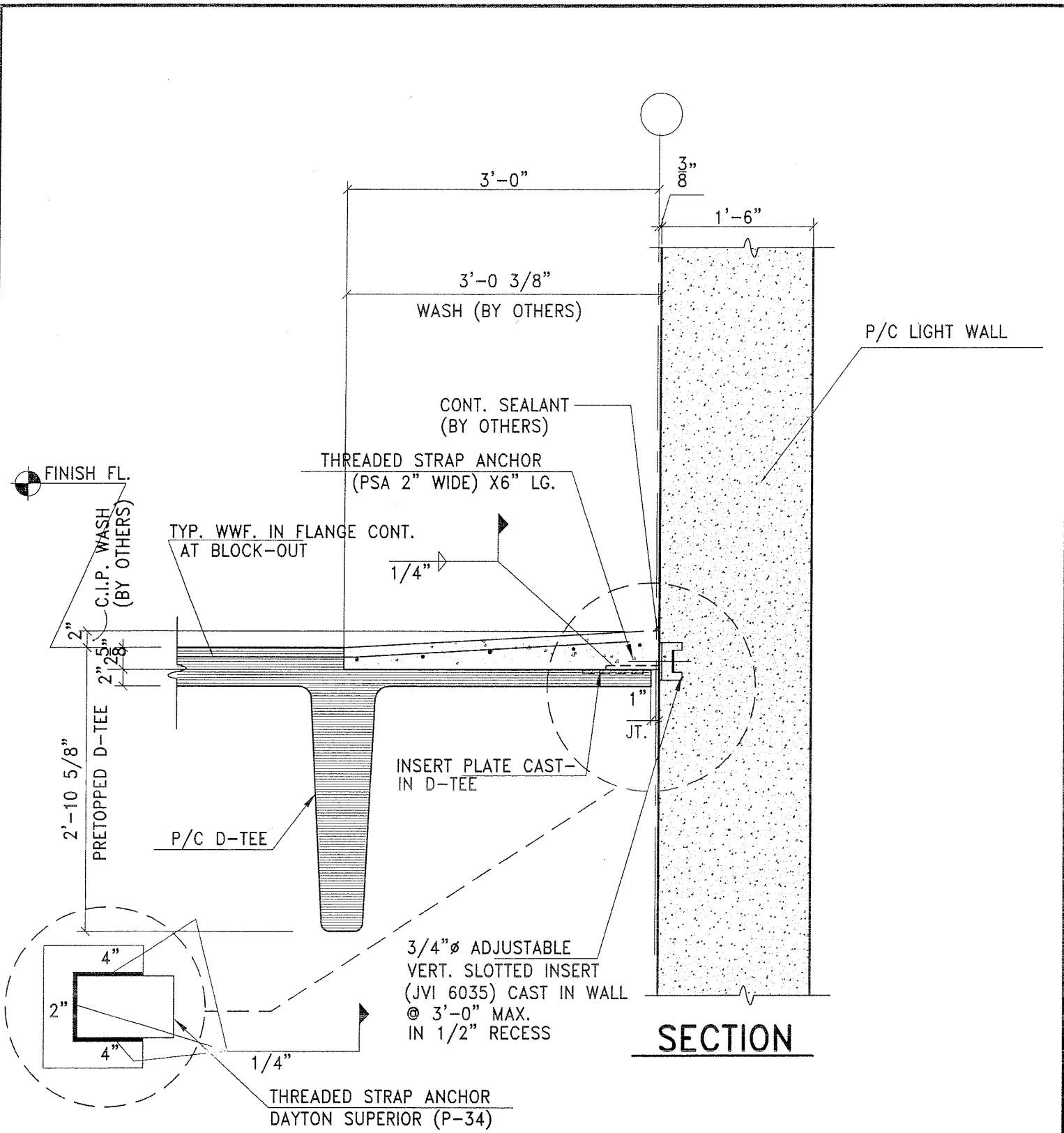

# TYP. D-TEE-NON-BEARING WALL CONNECTION

SCALE: 3/4" = 1'-0"

**STRESS-CON**  
INDUSTRIES, INC.

MAIN OFFICE:  
50500 DESIGN LANE TEL: (586) 731-1628  
SHELBY TOWNSHIP, MI 48315 FAX: (586) 731-7007  
WWW.STRESSCONINDUSTRIES.COM

PROJECT NO.		DRAWN
SCALE		CHECKED
DATE	ISSUED FOR	REF.
		SHEET NO.

PROJECT

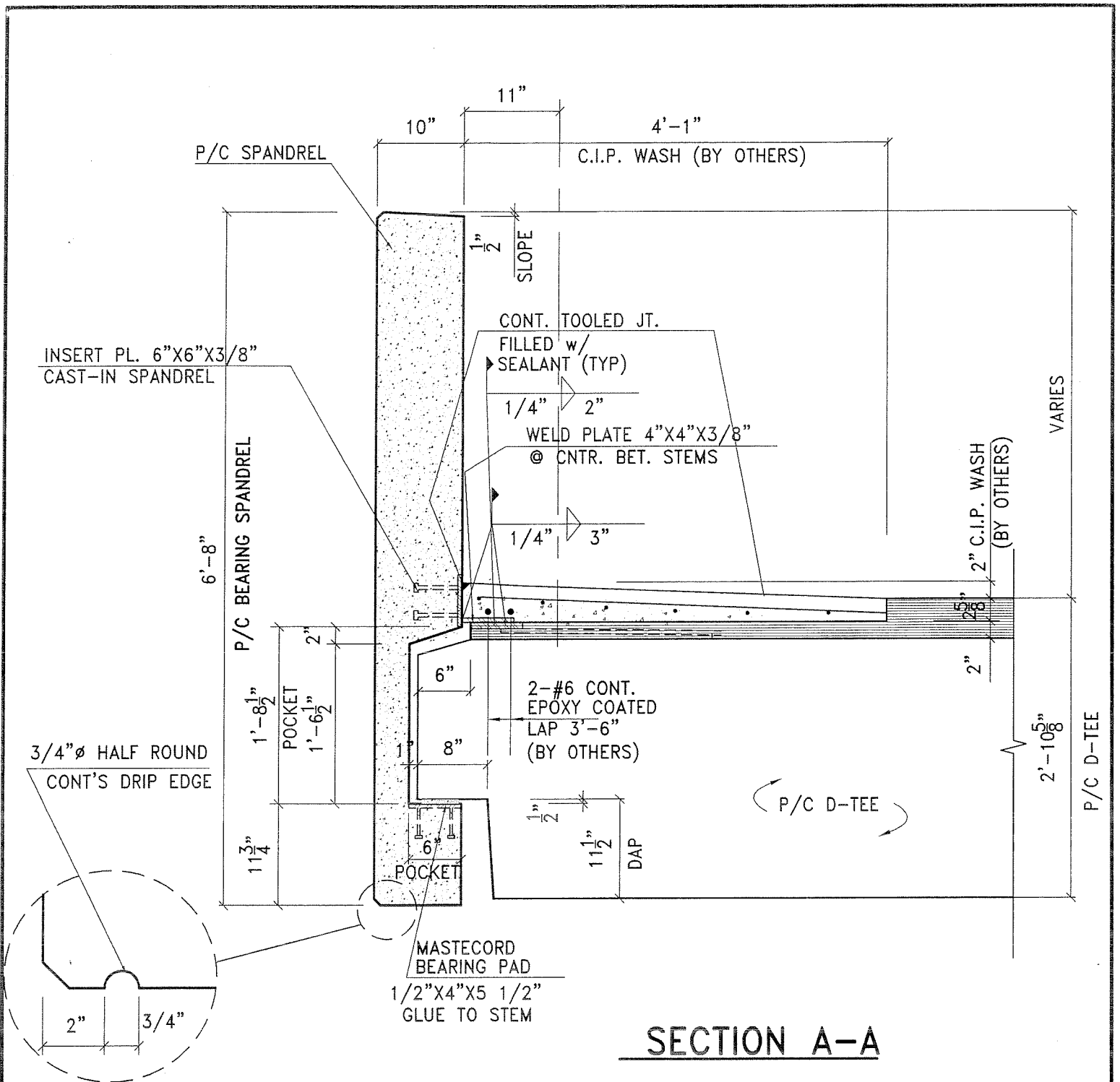

**TYP. D-TEE-SPANDREL CONNECTION**  
 SCALE: 3/4" = 1'-0"      © CNTR. BET. STEMS

PROJECT	<b>STRESS-CON INDUSTRIES, INC.</b> MAIN OFFICE: 50500 DESIGN LANE SHELBY TOWNSHIP, MI 48315 TEL: (586) 731-1628 FAX: (586) 731-7007 WWW.STRESSCONINDUSTRIES.COM	PROJECT NO.		DRAWN
		SCALE		CHECKED
		DATE	ISSUED FOR	REF.
				SHEET NO.

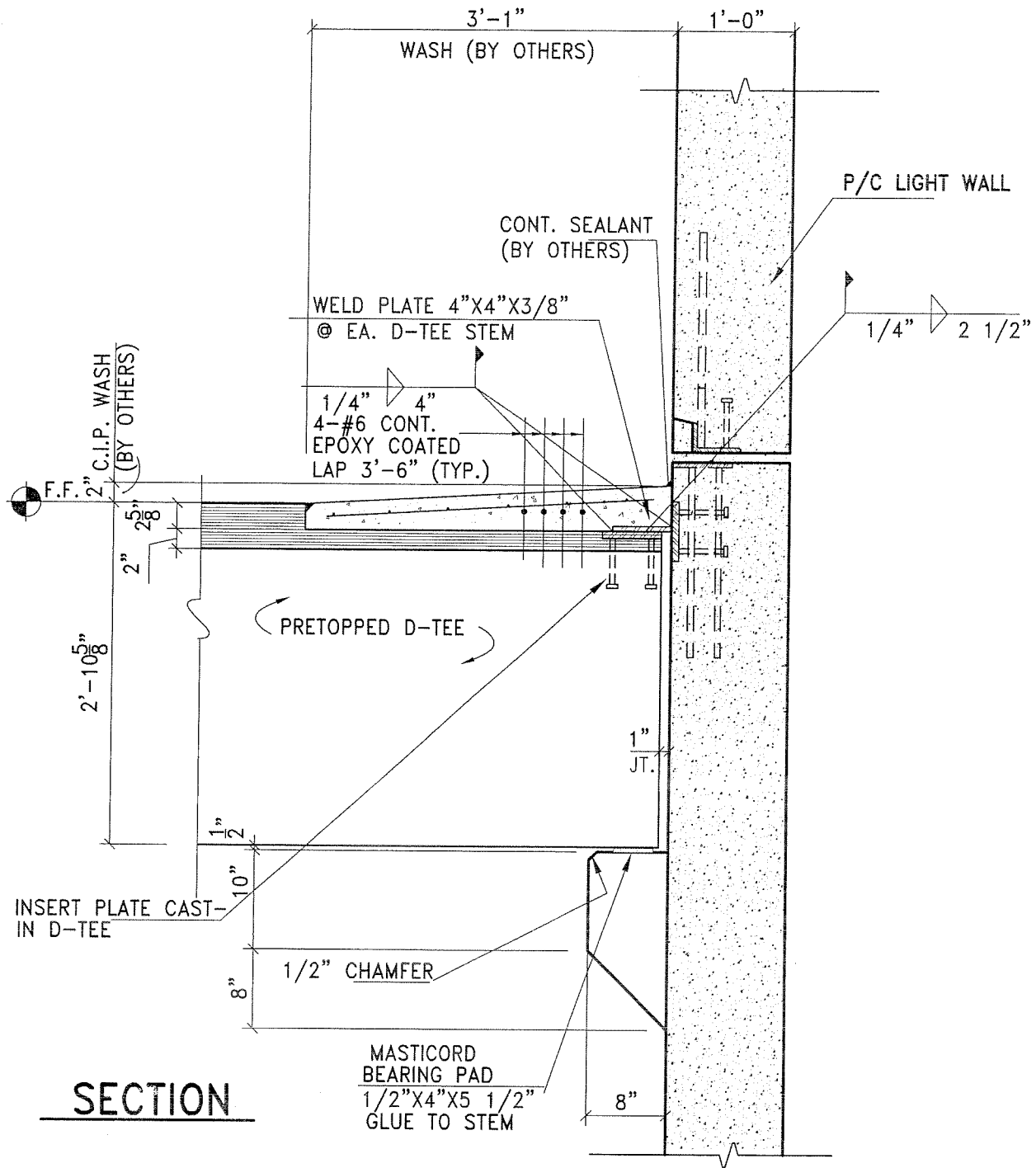

## TYP. TEE-BEARING / LIGHT WALL CONNECTION

SCALE: 3/4" = 1'-0"

**STRESS-CON**   
INDUSTRIES, INC.

MAIN OFFICE:  
50500 DESIGN LANE TEL: (586) 731-1628  
SHELBY TOWNSHIP, MI 48315 FAX: (586) 731-7007  
WWW.STRESSCONINDUSTRIES.COM

PROJECT NO.

DRAWN

SCALE

CHECKED

DATE

ISSUED FOR

REF.

PROJECT

SHEET NO.

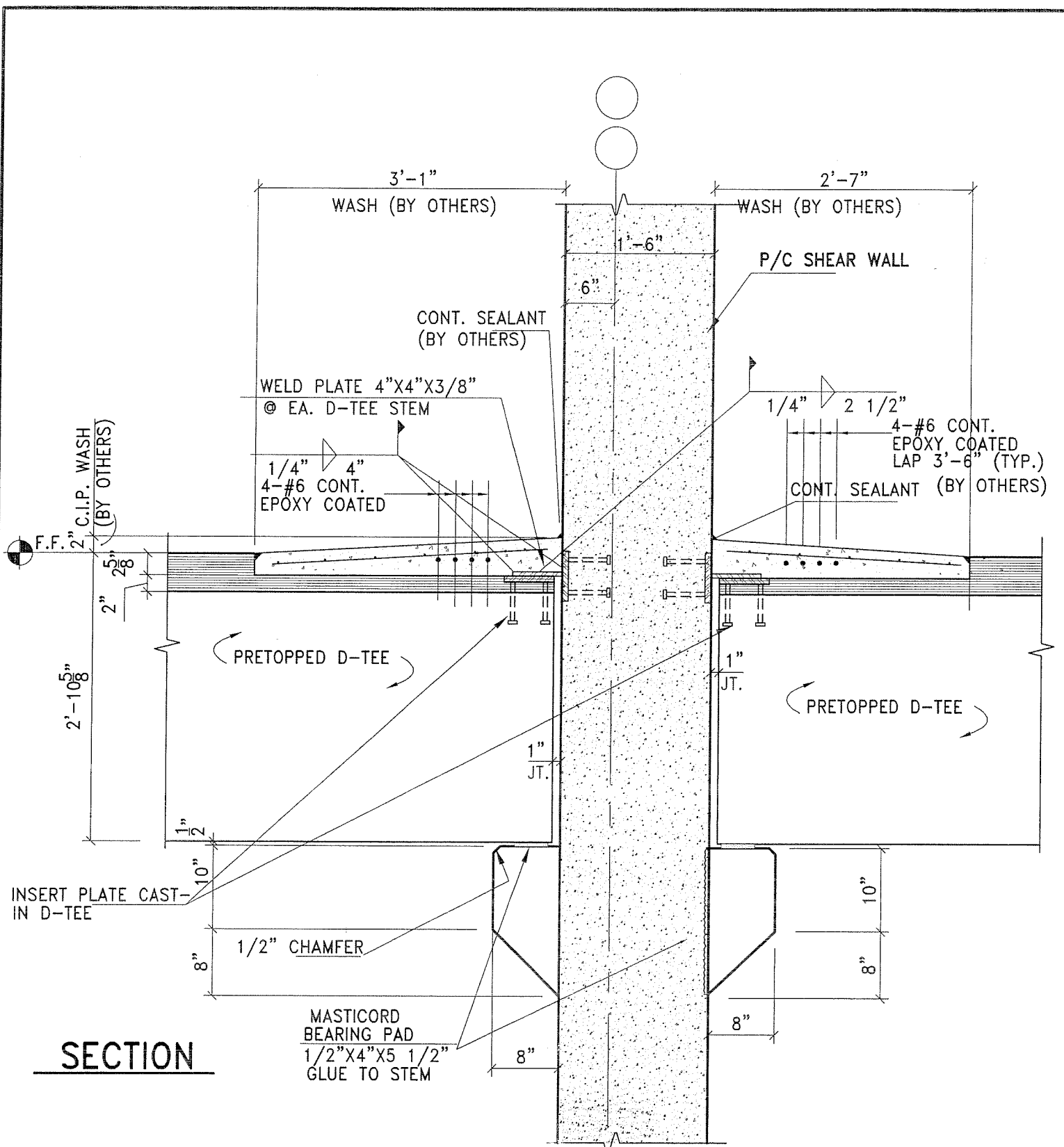

**SECTION**

**TYP. TEE-BEARING / SHEAR WALL CONN**

SCALE: 3/4" = 1'-0"

**STRESS-CON**  
INDUSTRIES, INC.

MAIN OFFICE:  
50500 DESIGN LANE TEL: (586) 731-1628  
SHELBY TOWNSHIP, MI 48315 FAX: (586) 731-7007  
WWW.STRESSCONINDUSTRIES.COM

PROJECT NO.		DRAWN
SCALE		CHECKED
DATE	ISSUED FOR	REF.
		SHEET NO.

PROJECT